

PUMP & FILTRATION SYSTEMS >



## High quality polymer filtration

Vessel and piston technologies



MAAG offers all filtration technologies for large scale polymer applications. The scope of supply includes a wide range of piston type screenchangers, and customized vessel filters in any size and execution. For each application, the MAAG team and the customer investigate the optimal filter solution according to the process, installation environment and filter handling demands.

### Benefits

- Choice of customized large scale piston filter or large area vessel filter execution
- Candle filter elements for gel retention up to 255 m<sup>2</sup> (2749 ft<sup>2</sup>) filter surface
- Curved mesh screens for one-way use up to 3,5 m<sup>2</sup> (37 ft<sup>2</sup>) filter surface
- Rheologically optimized flow channel design for low  $\Delta P$  and short residence time
- Sturdy and reliable filter execution for safe operation and simple handling
- Covered by MAAG's worldwide start-up, parts and field service support

# MAAG piston filter technology

## Large scale screen changer with candle filter elements or curved meshscreens

The modular filter design offers an interchangeable piston execution according to the application. The piston cavity is available with candle filter elements for gel retention, or curved mesh screens for one-way use as well. With several filter sizes and the choice of 1, 2, or 4 pistons the range of screen changer meet all requirements for large scale polymer filtration.

### **CSC-C Screen changer with candle filter elements**

MAAG's CSC-C large scale screen changer with candle filter elements is the right choice if short melt residence time, small footprint and a simplified candle change are required.

Depending on the polymer type, melt viscosity, reactor throughput, and filter fineness, the screen changer size and number of pistons are customized to the application.

The patented design allows the use of pleated micronex® candle filter elements with fiber metal felt (FMF) media, or cylindrical Multinex candles filter elements with interchangeable filter sleeves.

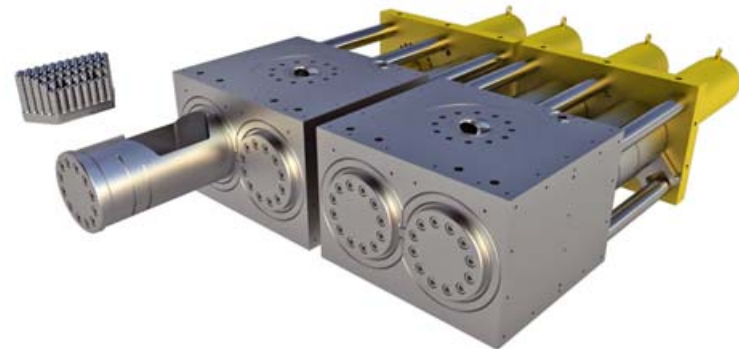

Screen changer with candle filter elements

### **CSC-R Screen changer with curved filter screens**

MAAG's CSC-R large scale screen changer with curved screens is designed for the use of one-way filter screens which do not require cleaning after the simple and safe screen change.

The screen bearing pistons belong to MAAG's modular filter system and its patented design use 75% of the piston surface as active filtration area.

Also this filter execution can be installed for vertical or horizontal melt flow directly at the reactor discharge melt pump or pelletizer booster melt pump to avoid additional piping for reduction of melt residence time.

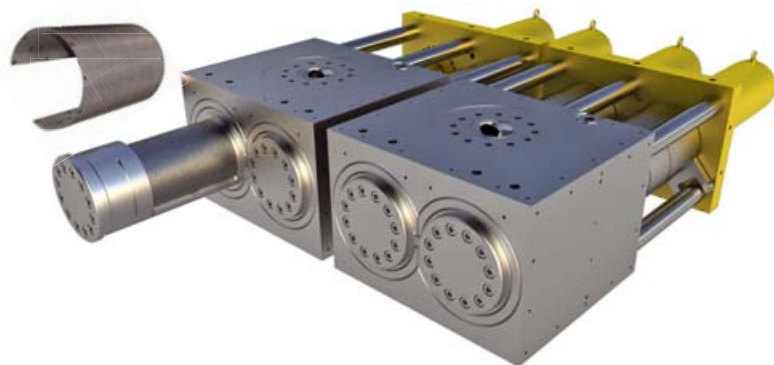

Screen changer with curved filter screens

# MAAG vessel filter technology

## Large scale vessel filter with external or integrated switch over valve

The proven large scale vessel technology is available as continuous duplex twin vessel execution in all sizes according to flux rate, filter fineness and media requirements, and as simplex single vessel execution for batch applications as well. The duplex filter design can be executed with external or integrated switch over valve, according to the installation and handling demands.



Filter vessel with external 3-way valve (piston design)

### **duplex-PV Filter vessel with external 3-way valve (piston design)**

MAAG duplex-PV is the cost-effective large area filtration series with direct bolted switch over valves.

The external arrangement of the 3-way piston valves allows easy access for handling and maintenance.

The standard version uses C-clamps on the vessel cover for fast cover removal and exchange of the candle bundles.

As an option the duplex-PV is available with jack bolts for safe and fast exchange of the complete vessel assembly.



Filter vessel with integrated 3-way valve (slide plate design)

### **duplex-DV Filter vessel with integrated 3-way valve (slide plate design)**

MAAG duplex-DV is the compact large area filtration series with integrated divex® switchover valves.

The internal arrangement of the patented slide plate valves leads to a small system foot print.

The sturdy system frame with jack bolt sealing units allows an easy and safe change of the complete filter vessels.

The reliable sealing of the valve / vessel connection of the duplex-DV is guaranteed by metal O-rings and the seating force of the jack bolt units.

# MAAG piston filter technology

## CSC-C screen changer with candle filter elements

Continuous CSC-C screen changers from MAAG, with their robust and leak-free operation, meet the highest quality standards. The sturdy design is based on the proven double or quad piston design that operates reliably without any additional seals. On the filter inlet side, rheologically optimized flow channels divide the melt stream into the 2 or 4 pistons in equal parts. Downstream of the candle filter elements, the cleaned partial melt streams converge again and flow out of the filter housing as on single polymer stream.

### Change of filter candles

To change the candle bundles, each piston moves out separately, driven by a hydraulic cylinder. Once its candle filter elements are changed, the piston returns to its production position in the same way.

An automated and effective cavity venting process prevents air from entering into the melt flow. During the fast candle change procedure, the melt continues to flow through the remaining pistons to ensure a continuous melt flow and constant polymer throughput.

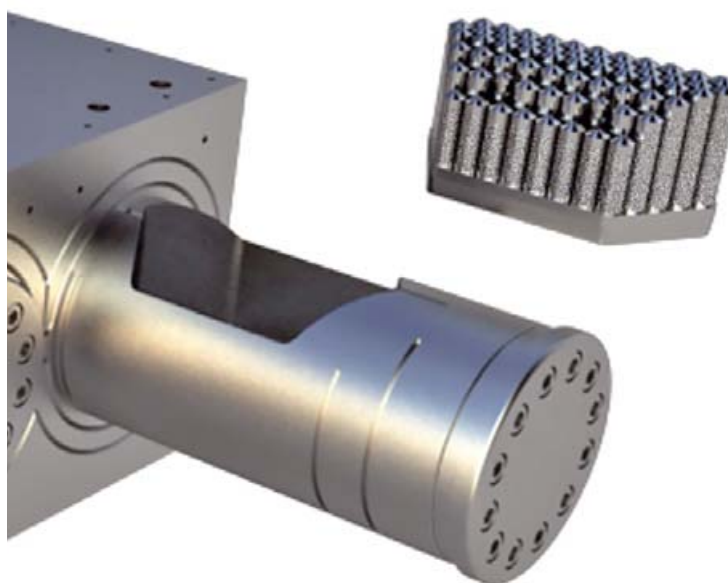

### CSC-C range of sizes

2-piston execution

Filter size	CSC-200/C	CSC-230/C	CSC-250/C	CSC-270/C	CSC-300/C	CSC-340/C	CSC-400/C	CSC-460/C
<b>Candles per piston:</b>	34	34	34	39	44	65	88	124
<b>Filter area per piston:</b>	1,10 m <sup>2</sup>	1,43 m <sup>2</sup>	1,58 m <sup>2</sup>	2,05 m <sup>2</sup>	2,55 m <sup>2</sup>	4,27 m <sup>2</sup>	6,65 m <sup>2</sup>	13,52 m <sup>2</sup>
<b>Filter area total filter:</b>	2,20 m <sup>2</sup> (23,7 ft <sup>2</sup> )	2,86 m <sup>2</sup> (30,8 ft <sup>2</sup> )	3,16 m <sup>2</sup> (34,0 ft <sup>2</sup> )	4,10 m <sup>2</sup> (44,1 ft <sup>2</sup> )	5,10 m <sup>2</sup> (54,9 ft <sup>2</sup> )	8,54 m <sup>2</sup> (91,9 ft <sup>2</sup> )	13,30 m <sup>2</sup> (143,2 ft <sup>2</sup> )	27,04 m <sup>2</sup> (291,1 ft <sup>2</sup> )

### CSC-C range of sizes

4-piston execution

Filter size	CSC-200/C	CSC-230/C	CSC-250/C	CSC-270/C	CSC-300/C	CSC-340/C	CSC-400/C	CSC-460/C
<b>Candles per piston:</b>	34	34	34	39	44	65	88	124
<b>Filter area per piston:</b>	1,10 m <sup>2</sup>	1,43 m <sup>2</sup>	1,58 m <sup>2</sup>	2,05 m <sup>2</sup>	2,55 m <sup>2</sup>	4,27 m <sup>2</sup>	6,65 m <sup>2</sup>	13,52 m <sup>2</sup>
<b>Filter area total filter:</b>	4,20 m <sup>2</sup> (45,2 ft <sup>2</sup> )	5,72 m <sup>2</sup> (61,6 ft <sup>2</sup> )	6,62 m <sup>2</sup> (68,0 ft <sup>2</sup> )	8,20 m <sup>2</sup> (88,2 ft <sup>2</sup> )	10,20 m <sup>2</sup> (109,8 ft <sup>2</sup> )	17,08 m <sup>2</sup> (183,8 ft <sup>2</sup> )	26,60 m <sup>2</sup> (286,4 ft <sup>2</sup> )	54,08 m <sup>2</sup> (582,2 ft <sup>2</sup> )

For discontinuous and batch filter applications all filter sizes are available as **DSC/C** single piston execution.

According to the flow piping, **DSC/C** filter can be installed in horizontal or vertical position.

# MAAG piston filter technology

## CSC-C candle filter elements

The patented hexagonal pattern of the candles allows a maximized active filtration surface inside each piston cavity.

### CSC-C candle filter elements

The amount, design, and filter media of the candle filter elements are tailor-made in regards of polymer type, melt viscosity, and filter fineness. According to the application, a typical demand for CSC-C candle filter elements is to remove solid black spots or soft gel contamination.

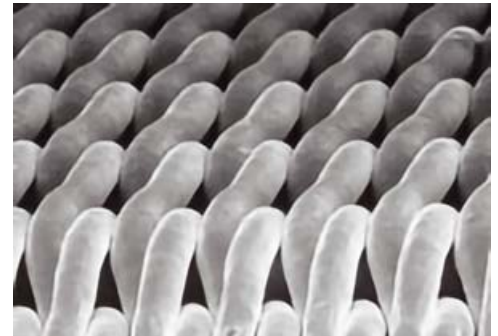

Wire screen

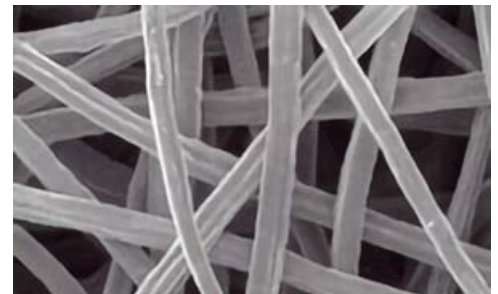

Fiber metal felt

### CSC-C candle replacement

- The used candle bundle can be lifted easily with a gripper and a light-weight crane out of the piston cavity, followed by the installation of the new candle bundle out of the pre-heat oven into the empty piston cavity.
- The piston then moves into the filter housing, accompanied by an automated venting of the candle filter elements, and is followed by the candle change of the next pistons.
- The candle change procedure requires only 15 min per piston and can be safely executed by two operators without influence to the continuous production process.



Exchange of candle bundle



Sectional view of candle installation

# MAAG piston filter technology

## CSC-R screen changer with curved filter screens

Continuous CSC-R screen changers from MAAG, with their robust and leak-free operation, meet highest quality standards. The sturdy design is based on the proven double or quad piston design that operates reliably without any additional seals. On the filter inlet side, rheological optimized flow channels divide the melt stream into the 2 or 4 pistons at equal parts. Downstream of the curved screens, the cleaned partial melt streams converge again and flow out of the filter housing as a single polymer stream.

### Change of curved screens

To change the curved screens, each piston moves out separately, driven by a hydraulic cylinder. Once its screen is changed, the piston returns to its production position in the same way.

An automated and effective cavity venting process prevents air from entering into the melt flow. During the fast screen change procedure, the melt continues to flow through the remaining pistons to ensure a continuous melt flow and constant polymer throughput.

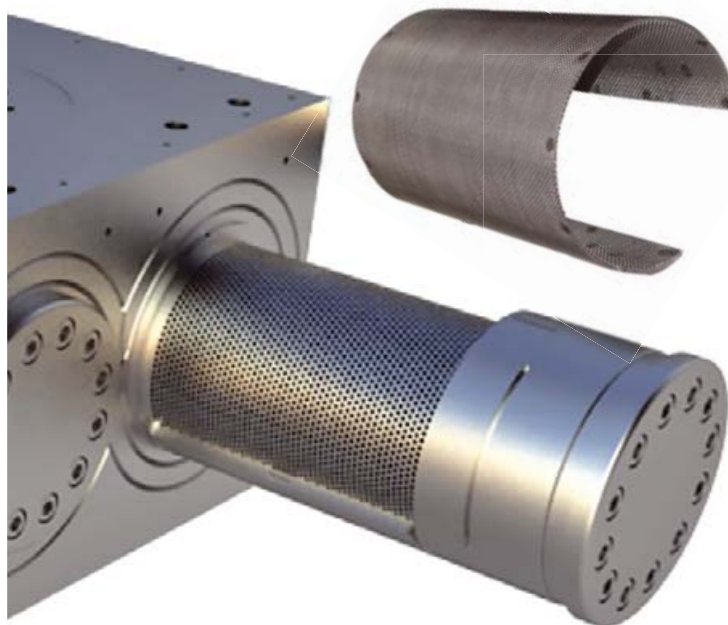

### CSC-R range of sizes

2-piston execution

Filter size	CSC-200/R	CSC-230/R	CSC-250/R	CSC-270/R	CSC-300/R	CSC-340/R	CSC-400/R	CSC-520/R
<b>Filter area per piston:</b>	1386 cm <sup>2</sup>	1768 cm <sup>2</sup>	2157 cm <sup>2</sup>	2559 cm <sup>2</sup>	3058 cm <sup>2</sup>	3979 cm <sup>2</sup>	4887 cm <sup>2</sup>	8622 cm <sup>2</sup>
<b>Filter area total filter:</b>	0,28 m <sup>2</sup> (3,0 ft <sup>2</sup> )	0,35 m <sup>2</sup> (3,8 ft <sup>2</sup> )	0,43 m <sup>2</sup> (4,6 ft <sup>2</sup> )	0,51 m <sup>2</sup> (5,5 ft <sup>2</sup> )	0,61 m <sup>2</sup> (6,6 ft <sup>2</sup> )	0,80 m <sup>2</sup> (8,6 ft <sup>2</sup> )	0,98 m <sup>2</sup> (10,5 ft <sup>2</sup> )	1,72 m <sup>2</sup> (18,6 ft <sup>2</sup> )

### CSC-R range of sizes

4-piston execution

Filter size	CSC-200/R	CSC-230/R	CSC-250/R	CSC-270/R	CSC-300/R	CSC-340/R	CSC-400/R	CSC-520/R
<b>Filter area per piston:</b>	1386 cm <sup>2</sup>	1768 cm <sup>2</sup>	2157 cm <sup>2</sup>	2559 cm <sup>2</sup>	3058 cm <sup>2</sup>	3979 cm <sup>2</sup>	4887 cm <sup>2</sup>	8622 cm <sup>2</sup>
<b>Filter area total filter:</b>	0,56 m <sup>2</sup> (6,0 ft <sup>2</sup> )	0,70 m <sup>2</sup> (7,6 ft <sup>2</sup> )	0,86 m <sup>2</sup> (9,3 ft <sup>2</sup> )	1,02 m <sup>2</sup> (11,0 ft <sup>2</sup> )	1,22 m <sup>2</sup> (13,2 ft <sup>2</sup> )	1,60 m <sup>2</sup> (17,1 ft <sup>2</sup> )	1,96 m <sup>2</sup> (21,0 ft <sup>2</sup> )	3,44 m <sup>2</sup> (37,1 ft <sup>2</sup> )

For discontinuous and batch filter applications all filter sizes are available as **DSC/R** single piston execution. According to the flow piping, **DSC/R** filter can be installed in horizontal or vertical position.

# MAAG piston filter technology

## CSC-R curved filter screens

The patented curved screens are pre-formed to fit tight on the breaker plate and ensure a fail-safe sealing at the complete rim.

### CSC-R curved filter screens

The amount of screen layers, weave type, or fiber metal felt (FMF) of the curved screens are tailor-made in regards of polymer type, melt viscosity and filter fineness. According to the application, a typical demand for CSC-R screens is to retain reliable solid black spot contaminations at a high flux rate.

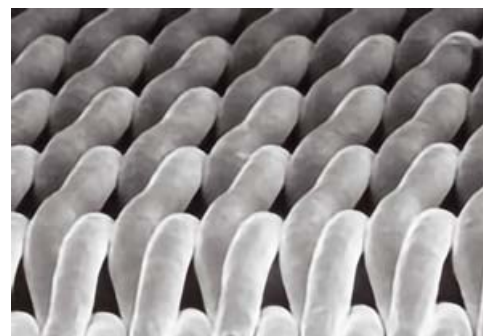

Wire screen



Fiber metal felt

### CSC-R curved filter replacement

- The used curved screen can be peeled off the breaker plate. The one-way screens are intended for disposal without the need of cleaning effort. Followed by the simple attachment of a new curved screen on the breaker plate, the screen change procedure is finished.
- The piston then moves into the filter housing, accompanied by an automated venting of the curved screen cavity, and is followed by the screen change of the next pistons.
- The screen change procedure requires only 15 min per piston and can be safely executed by two operators without influencing the continuous production process.



Screen assembly (CSC-R installed for horizontal melt flow)



Screen assembly (CSC-R installed for vertical melt flow)

# MAAG piston filter technology

## CSC-C and CSC-R Installation

MAAG large scale screen changers can be installed for vertical or horizontal melt flow directly at the reactor discharge melt pump or pelletizer booster melt pump. The direct assembly of the screen changer to other process components without additional piping ensures the shortest possible line length and melt residence time between the extruder or reactor and the pelletizer.

### Horizontal melt flow installation Operator side left

- Inlet MAAG extrex® booster pump
- Outlet MAAG SPHERO® underwater pelletizer



### Horizontal melt flow installation Operator side right

- Inlet MAAG extrex® booster pump
- Outlet MAAG SPHERO® underwater pelletizer



### Vertical melt flow installation Operator side front

- Inlet for direct assembly of MAAG vacorex® discharge polymer pump





# MAAG piston filter technology

## CSC-C and CSC-R Controls

MAAG control units for large scale screen changers are built for simple operating by self-explaining user guidance which push-buttons and monitoring of all filter functions. Its sturdy and reliable execution is tailor-made to the plant installation and consider the individual demands of the application.

### Operator panel, located at the screen changer

- Color touch panel
- With push-buttons and control lights for operating
- Execution ex-proof with protection class available

### Control cabinet, located outside ex-proof area

- PLC (SPS) with manual and automatic mode
- Automatic piston positioning for filter change and cavity venting
- Cyclic micro-movement of pistons
- Monitoring of piston position
- Digital signal interface for safety interlocks
- 2 inputs 4-20mA for melt pressure signals
- Optional ProfiNet interface for customer DCS
- Protection class IP54



Operator panel

### CSC-C and CSC-R Safety measures

Depending on the installation position of the screen changer, handling demands and the plant layout, MAAG offers a wide range of reliable and certified safety devices.

Example of rolling safety guard at operator side with mechanical latch and safety switch interlock to the hydraulic power unit



Example of fenced operator area with mechanical door latch and safety switch interlock to the hydraulic power unit



# MAAG vessel filter technology

## duplex-PV large area candle filter

MAAG's duplex polymer filtration systems are designed with considerable input from our customers.

### LAF-System duplex

The proven duplex-PV execution with external change over piston valves offers easy access and safe operation.

Out of a modular system, the filter execution can be adjusted tailor-made to any filtration area, polymer type, filtration fineness and viscosity.

Based on the application, the duplex filter is designed with rheologically optimized flow channels for minimized residence time, providing seamless transfer and reliable sealing.

Our filtration systems are covered by worldwide parts and field service support.



duplex-PV large area candle filter

### duplex-PV range of sizes

Examples of a typical candle bundle per filter vessel <sup>1)</sup>

duplex size	DFS 5-7 PV	DFS 7-7 PV	DFS 11-19 PV	DFS 14-19 PV	DFS 20-19 PV	DFS 28-19 PV
<b>Filtration area per bundle:</b>	5,1 m <sup>2</sup> (54,9 ft <sup>2</sup> )	7,1 m <sup>2</sup> (76,4 ft <sup>2</sup> )	11,9 m <sup>2</sup> (128,1 ft <sup>2</sup> )	14,4 m <sup>2</sup> (155,0 ft <sup>2</sup> )	19,4 m <sup>2</sup> (208,8 ft <sup>2</sup> )	28,0 m <sup>2</sup> (301,4 ft <sup>2</sup> )
<b>Amount of candles:</b>	7	7	19	19	19	37
<b>Length of candles:</b>	711 mm (28")	1000 mm (39,37")	609 mm (24")	736 mm (29")	1000 mm (39,37")	736 mm (29")

duplex size	DFS 45-37 PV	DFS 63-67 PV	DFS 92-61 PV	DFS 137-91 PV	DFS 192-127 PV	DFS 255-169 PV
<b>Filtration area per bundle:</b>	45,4 m <sup>2</sup> (488,7 ft <sup>2</sup> )	63,2 m <sup>2</sup> (680,3 ft <sup>2</sup> )	92,2 m <sup>2</sup> (992,4 ft <sup>2</sup> )	137,5 m <sup>2</sup> (1480,0 ft <sup>2</sup> )	192,0 m <sup>2</sup> (2066,7 ft <sup>2</sup> )	255,4 m <sup>2</sup> (2749,1 ft <sup>2</sup> )
<b>Amount of candles:</b>	37	61	61	91	127	169
<b>Length of candles:</b>	1200 mm (47,24")	1016 mm (40")	1473 mm (58")	1473 mm (58")	1473 mm (58")	1473 mm (58")

<sup>1)</sup> Candle filter elements made with dia. 2,413" (61,3 mm) and pleat height 0,387" (9,83 mm)

For discontinuous and batch filter applications all filter sizes are available as **simplex** single vessel execution.

According to the flow piping, **simplex** filter can be installed in horizontal or vertical position.

For fast candle bundle exchange there are Pre Heat Stations and Vessel Rotating Devices available.

# MAAG vessel filter technology

## duplex-PV with piston valves

MAAG duplex filter units are equipped with 3-way switch over valves and drain or vent valves from leading suppliers.



MAAG duplex filter unit with piston valves

### duplex-PV handling options

The standard version of the duplex-PV series is equipped with direct bolted switch over valves.

The connection of the upper 3-way valve is made with a C-clamp connector for simple and fast disconnection of the vessel cover.

Once the vessel cover is removed, the soiled candle bundle can be lifted out of the remaining vessel for exchange with a clean candle bundle.

As an option, the duplex-PV filter units are equipped with jack bolt units for disconnection of the 3-way valves without the need to disconnect the vessel process connections.

Once both jack bolt units are unfastened, the complete vessel assembly can be exchanged for a new vessel.

The jack bolt units are positioned outside the system frame for easy and safe access.

### duplex valves

Their sturdy and reliable design is sized to the application and offers a reliable and safe operation.

Depending on the handling and access requirements, the valves can be executed for manual operation or with electric actuators and position control.

All valve units are backed by MAAG's quality control, spare parts service and guarantee.



Equipped with direct bolted switch over valves

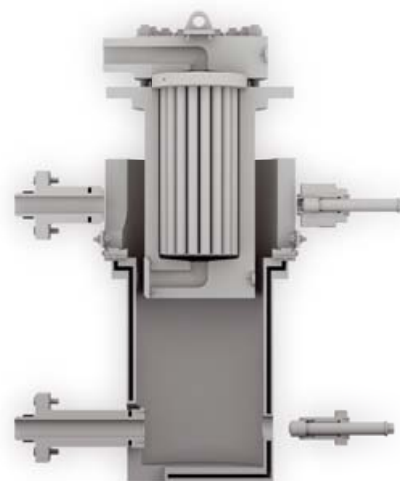

Equipped with jack bolt units for disconnection of the 3-way valves

# MAAG vessel filter technology

## duplex-DV large area candle filter

The duplex-DV filtration system is executed with a sturdy single frame for both vessels.

### divex change over

The divex change over valve is arranged between the vessels and does not need an additional valve support frame.

This filter system generally is equipped with jack bolt sealing units to ensure a fast and safe vessel change procedure.

The integrated slide-plate based divex valve shortens the piping length of the flow channels and ensures a minimized polymer dwell time and provides together, with the single frame design, a small installation size.



duplex-DV large area candle filter

### duplex-DV range of sizes

Examples of typical candle bundles per filter vessel <sup>1)</sup>

duplex size	DFS 5-7 DV	DFS 7-7 DV	DFS 11-19 DV	DFS 14-19 DV	DFS 20-19 DV	DFS 28-19 DV
<b>Filtration area per bundle:</b>	5,1 m <sup>2</sup> (54,9 ft <sup>2</sup> )	7,1 m <sup>2</sup> (76,4 ft <sup>2</sup> )	11,9 m <sup>2</sup> (128,1 ft <sup>2</sup> )	14,4 m <sup>2</sup> (155,0 ft <sup>2</sup> )	19,4 m <sup>2</sup> (208,8 ft <sup>2</sup> )	28,0 m <sup>2</sup> (301,4 ft <sup>2</sup> )
<b>Amount of candles:</b>	7	7	19	19	19	37
<b>Length of candles:</b>	711 mm (28")	1000 mm (39,37")	609 mm (24")	736 mm (29")	1000 mm (39,37")	736 mm (29")

duplex size	DFS 45-37 DV	DFS 63-67 DV	DFS 92-61 DV	DFS 137-91 DV	DFS 192-127 DV	DFS 255-169 DV
<b>Filtration area per bundle:</b>	45,4 m <sup>2</sup> (488,7 ft <sup>2</sup> )	63,2 m <sup>2</sup> (680,3 ft <sup>2</sup> )	92,2 m <sup>2</sup> (992,4 ft <sup>2</sup> )	137,5 m <sup>2</sup> (1480,0 ft <sup>2</sup> )	192,0 m <sup>2</sup> (2066,7 ft <sup>2</sup> )	255,4 m <sup>2</sup> (2749,1 ft <sup>2</sup> )
<b>Amount of candles:</b>	37	61	61	91	127	169
<b>Length of candles:</b>	1200 mm (47,24")	1016 mm (40")	1473 mm (58")	1473 mm (58")	1473 mm (58")	1473 mm (58")

<sup>1)</sup> Candle filter elements made with dia. 2,413" (61,3 mm) and pleat height 0,387" (9,83 mm)

For discontinuous and batch filter applications all filter sizes are available as **simplex** single vessel execution.

According to the flow piping, **simplex** filter can be installed in horizontal or vertical position.

For fast candle bundle exchange there are Pre Heat Stations and Vessel Rotating Devices available.

# MAAG vessel filter technology

## duplex-DV slide-plate valve

The divex 3-way valve is a proven switch over valve for a seamless polymer transfer from one vessel to the other.



MAAG divex 3-way valve

### divex slide plate valve

Its metal-to-metal seal slide plate design needs no additional sealing gaskets and ensures minimal maintenance.

The flow channel design has no stagnation areas and is tailor-made designed for the required polymer viscosity and throughput. The divex execution generally is executed with an integrated heat jacket.

As an option, the hydraulically standard drive unit with position control can be executed with an electric motor.

### duplex-DV handling options

The standard version of the duplex-DV units are equipped with jack bolt units for disconnection of the 3-way valves without the need to disconnect the vessel process connections.

Once both jack bolt units are unfastened, the complete vessel assembly can be exchanged for a new vessel.

The jack bolt units are positioned outside the system frame for easy and safe access.

For applications which do not require a complete vessel change, the duplex-DV design allows candle bundle only removal.

For this handling option, only the upper jack bolt needs to be released and the cover bolting needs to be unfastened.

Once the vessel cover is removed, there is direct access for a crane to lift out the used candle bundle and replace with a clean candle bundle.

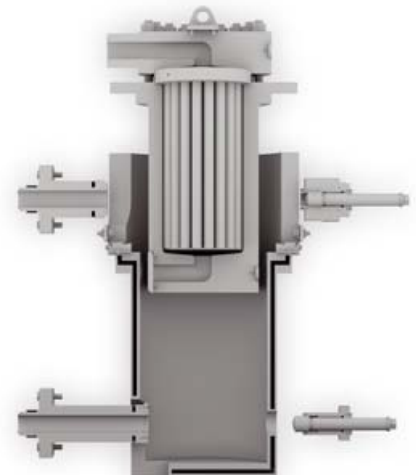

Equipped with jack bolt units for disconnection of the 3-way valves

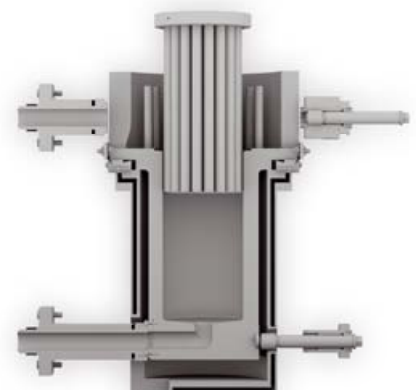

Equipped with direct bolted switch over valves

# MAAG vessel filter technology

## duplex-PV and duplex-DV candle filter elements

MAAG micronex® candle filter elements are designed to optimize the flow and to maximize the filter area. The production range offers all design variants for MAAG duplex and simplex filter and any other filter system in the market as well.

### Range of design

- Micron rating 0,5 to 200 µm absolute
- Candle length 16" up to 58"
- Melt pressures up to 300 bar
- Differential pressures up to 100 bar
- Temperatures up to 400 °C
- Optimized candle diameter and pleat height
- Media structure according to cleaning methods
- Flat wrap elements with cylindrical filter media
- Removable mesh packs for reuse of candle body



### Scope of supply

#### Media

MAAG offers hard or soft sintered fiber metal felt, or wire screen media supported on both sides by protective screens. The media can be pleated or flat wrap.

#### Guards

Several types of guards are available to protect the pleats during general handling and cleaning procedure, or to avoid pulsing during backflush cleaning.

#### End fittings

Any design of end fittings is available. For example, these are available with internal or external hex, open ends or clamped compression connections.

#### Materials

The candle element hardware, wire screen, and fiber metal felt are made from 316 stainless steel. Other metallurgies such as Hastelloy are also available. Threaded fittings are available in non-galling materials.

# MAAG vessel filter technology

## duplex-PV and duplex-DV controls

The control systems for MAAG's duplex filter are designed for a safe and bumpless vessel change over procedure.

### Controls

The basic operation is a semi-automatic transfer sequence where the actual fill position is controlled by the operator.

All of push buttons and switches for operation of the switch over valves are mounted on the front of the panel with indicator lights that give position and status of the valves.

Depending on the stage of expansion, the PLC panel visualizes the movement of both switch over valves and additionally each of the four vent and drain valves.

The movement of the polymer switch over valves is performed by a hydraulic or electric actuation system.

Depending on the execution, it consists 4 actuated hydraulic cylinder or electric gear drives with linear position transducers, limit switches and torque switches.

Depending on the ambient conditions, the control system can be executed for a safe industrial area or hazardous area.



Control systems for MAAG's duplex filter

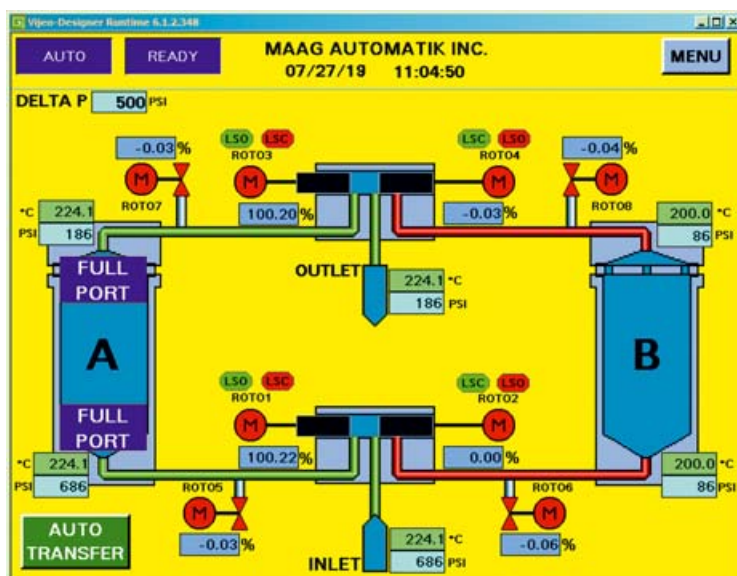

Control panel

The control panel incorporates a logic for a wide range of polymer throughputs, viscosities, and pressure drops, and displays to the operator all process data below:

### Filter system

- inlet and outlet pressure
- differential pressure
- inlet and outlet temperatures

### Vessel A

- inlet and outlet pressures
- inlet and outlet temperatures

### Vessel B

- inlet and outlet pressures
- inlet and outlet temperatures

### Switch over valves

- movement and position

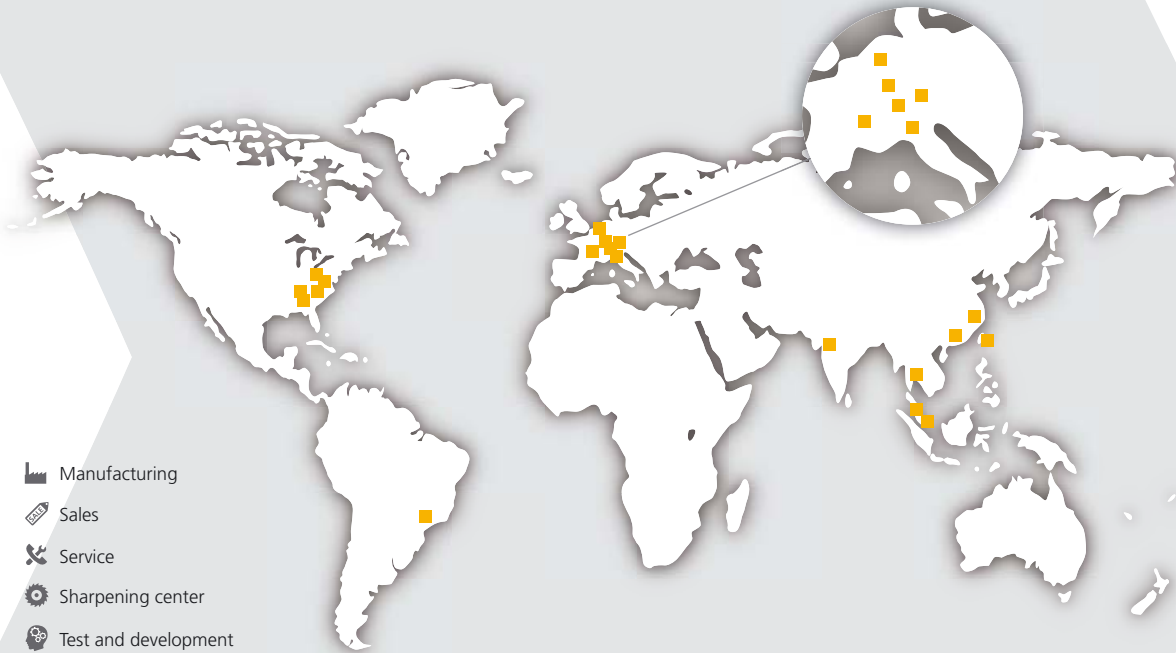

-  Manufacturing
-  Sales
-  Service
-  Sharpening center
-  Test and development

## Europe

### Headquarters in Switzerland

Maag Pump Systems AG  
Oberglatt  
+41 44 27882-00  
welcome@maag.com



### Germany

Maag Automatik GmbH  
Grossostheim  
+49 6026 503-0  
info@maag.com



Gala Kunststoff- und  
Kautschukmaschinen GmbH  
Xanten  
+49 2801 980-0  
maag.xan.info@maag.com



Maag Automatik GmbH  
Stuttgart  
+49 6026 503-442  
sales@maag.com



Ettlinger  
Kunststoffmaschinen GmbH  
Königsbrunn  
+49 8231 34908-00  
info.ettlinger@maag.com



### France

Maag Pump Systems SAS  
Villeurbanne  
+33 4 7268673-0  
MaagFrance@maag.com



### Italy

Maag Automatik s.r.l.  
Rozzano (MI)  
+39 02 5759321  
MaagItaly@maag.com



## Americas

### Brazil

Maag Automatik  
c/o Dover do Brasil  
Jundiaí – SP  
+55 11 292366-00  
InfoBrazil@maag.com



### USA

Ettlinger North America  
Atlanta, GA  
+1 770 703 8541  
info.ettlinger@maag.com



Maag Automatik, Inc.  
Charlotte, NC  
+1 704 7169000  
MaagAmericas@maag.com



Gala Industries, Inc.  
Eagle Rock, VA  
+1 540 8842589  
gala@gala-industries.com



Maag Automatik Inc.  
Kent, Ohio  
+1 330 6772225  
Maag.KEN.Info@maag.com



## Asia-Pacific

### China

Maag-Automatik Plastics  
Machinery (Shanghai) Co., Ltd.  
Jiading District, Shanghai,  
201802  
+86 21 8033 3200  
MaagChina@maag.com



Maag China Guangzhou Branch  
Huangpu District, Guangzhou  
510730  
+86 20 8985 0116  
MaagChina@maag.com



### India

Maag Automatik  
c/o Dover India Pvt. Ltd.  
Vadodara, Gujarat  
+91 960 175286-4 (-5)  
MaagIndia@maag.com



### Malaysia

Automatik Plastics Machinery  
Petaling Jaya Selangor  
+6 03 7842 2116  
InfoSEA@maag.com



### Singapore

Maag Systems Singapore  
Singapore 119843  
+65 6460 0160  
MaagSingapore@maag.com



### Taiwan

Maag Taiwan  
Taipei City 106  
+886 2 2703 6336  
InfoTaiwan@maag.com



### Thailand

Gala Industries Asia Limited.  
A. Sriracha, Chonburi  
+66 38 190840  
Maag.BKK.Information  
@maag.com



You can find detailed information about our products in our print media at [www.maag.com/brochures](http://www.maag.com/brochures).



PUMP & FILTRATION SYSTEMS >  MAAG  ETTLINGER  
 PELLETIZING SYSTEMS >  GALA  SCHEER  AUTOMATIK  
 PULVERIZING SYSTEMS >  REDUCTION  
 RECYCLING SYSTEMS >  ETTLINGER

[www.maag.com](http://www.maag.com)

